

Pressure Measurement

Basic Concepts

Pressure: the force F acting perpendicular to the unit area S

$$p = \frac{F}{S} = \frac{m \cdot g}{S} \quad (\text{Pa}; \text{kg}, \text{m} \cdot \text{s}^{-2}, \text{m}^2)$$

Hydrostatic pressure: the pressure of a column of liquid of height h and density ρ

$$p = \rho \cdot g \cdot h \quad (\text{Pa}; \text{kg} \cdot \text{mm})$$

Absolute pressure: measured from absolute zero

Vacuum: a large underpressure when the absolute pressure approaches zero

Overpressure and underpressure: measured from instantaneous barometric (atmospheric) pressure p_b

Total pressure: the sum of static pressure p_s and dynamic pressure p_d

$$p_t = p_s + p_d$$

Static pressure: the same throughout the flow cross-section

Dynamic pressure: depends on flow velocity and density

$$p_k = \rho \cdot w^2 / 2$$

Pressure Gauges Classification

- 1) hydrostatic
 - a. bell and piston gauges: the measure of pressure is the lift of the bell or the weight of a mass on a piston of known cross-section
 - b. liquid column gauges: the pressure measure is the height of the liquid column
- 2) deformation gauges: deformation of the elastic element
- 3) electrical gauges: change in electrical quantity

Bell Pressure Gauges

Principle: bell immersed in a liquid (water, kerosene, toluene, oil), the bell lift l is the measure of pressure

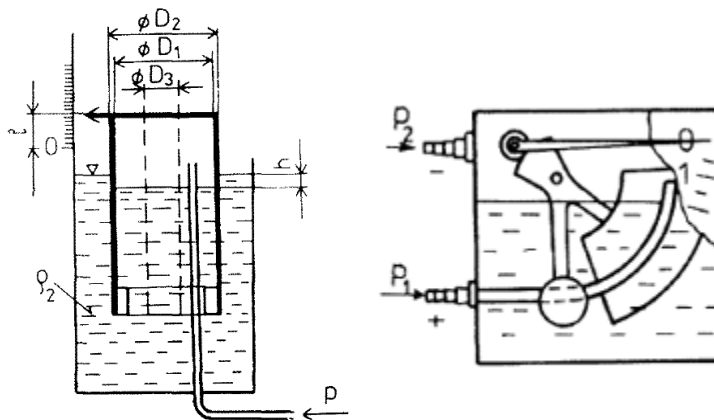

Application: static pressures up to 500 Pa, calibration of other pressure gauges

Piston Pressure Gauges

Principle: the weight of the piston G_p and the weight of a mass G_m create static pressure in the fluid

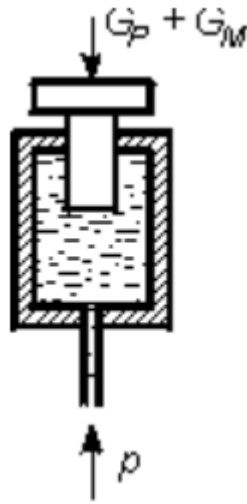

Application: calibration of deformation gauges, high pressures – up to GPa

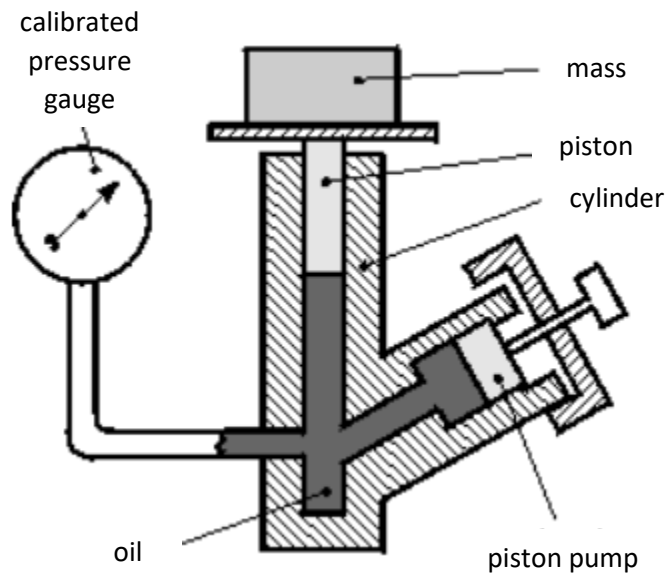

The calibration equipment includes a piston pressure gauge, pump, valves, and oil reservoir.

Calibration procedure:

- 1) Screw the pressure gauge to be verified into the fitting.
- 2) Opening the valve for the oil reservoir and sucking the pump into the system.
- 3) Closing the valve below the tank and opening the valve below the pressure gauge under test.
- 4) Placing a mass corresponding to the required pressure on the piston plate.
- 5) Pushing oil into the cylinder of the pressure gauge by the pump until the piston rises to the desired height.
- 6) Rotate the piston (guaranteeing liquid friction) and read the gauge reading.
- 7) Add weights, drop the piston, and repeat from step 5.

8) Construction of a deviation or correction chart.

Liquid Column Pressure Gauges

Principle: reading the height of the liquid column in tubes or basins; the pressure range and accuracy of the measurement depend on the pressure gauge medium (distilled water, mercury, alcohol) and the accuracy of the column height reading. The instantaneous density of the liquid affects the readings.

Classification:

- a) **U-tube manometers:** a glass (plastic) tube U-shaped or two straight tubes connected e.g., by a flexible element (rubber hose, etc.) half filled with liquid. The pressure difference $\Delta p = p_1 - p_2$ deflects the liquid by a measure of h . It is necessary to read the deflection of the column in both arms.

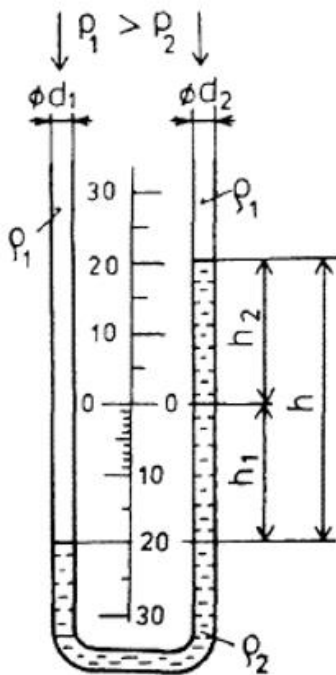

- a) **single-column manometer:** the deflection is read only in the tube (h). The drop in the level in the basin must be compensated for in the pressure gauge scale.

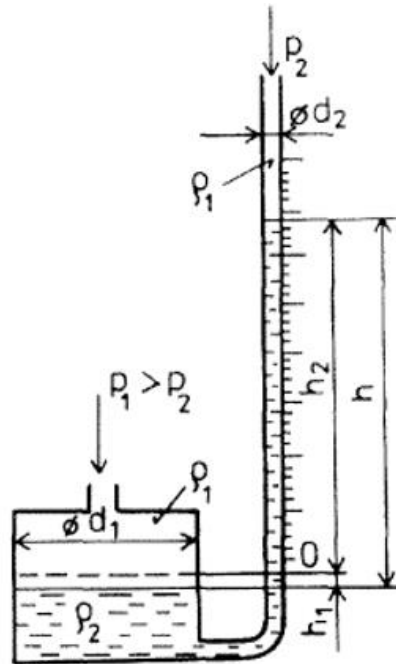

A variant of the single-column manometer is the **micromanometer inclined tube**. By tilting the scale tube, the sensitivity of the pressure gauge is increased.

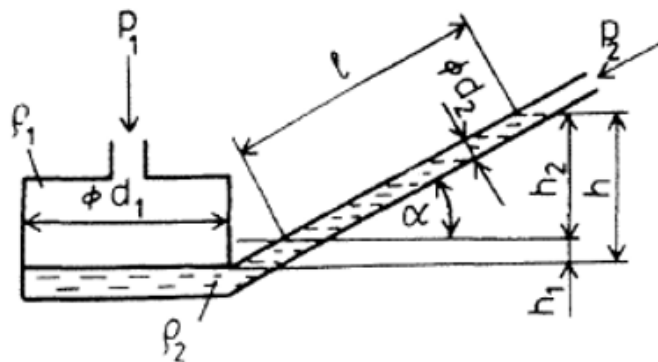

Deformation Pressure Gauges

Principle: elastic deformation and change of geometry of the pressure measuring element when pressure is applied

Advantages: robust design, small size and weight, large measuring range, sufficient accuracy, simplicity and reliability, easy operation and maintenance

Disadvantages: permanent deformation of the measuring element during operation, slight deformation of the measuring element (e.g., need to include mechanical gearing), influence of temperature on flexibility, need for calibration and verification.

Classification:

- a) **tubular (Bourdon) gauge:** for measuring vacuum, underpressure, and overpressure. The flattened, coiled flexible tube, closed at one end, is "straightened" by the incoming pressure, which deflects the dependent scale hand of the pressure gauge.

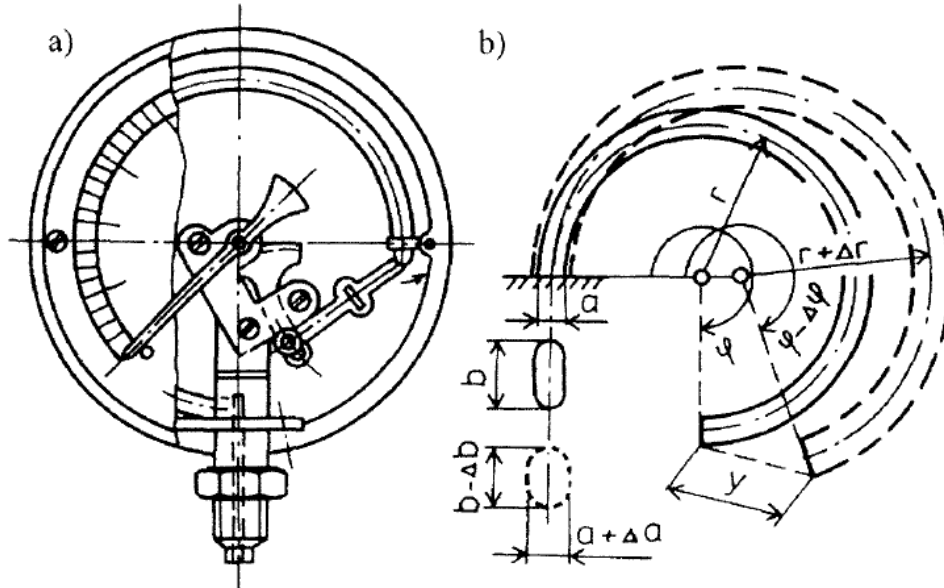

- b) **diaphragm gauge:** a flexible, circular diaphragm is bulged by the incoming pressure. This bulge is mechanically transferred to the pressure gauge scale hand.

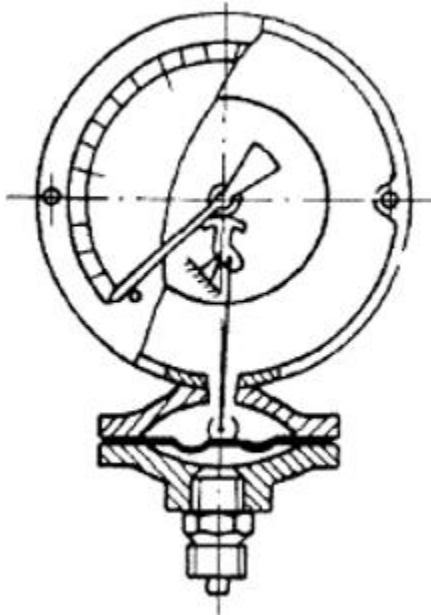

- c) **Box gauge:** a flat box, usually circular-shaped, the bottoms are formed by diaphragms; the deformation of the box is mechanically converted into a pressure indicator. Use for very low pressures.

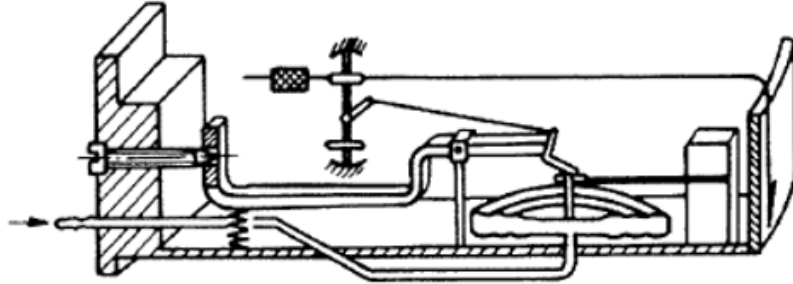

- d) **bellows gauge:** metal bellows placed in the measuring chamber. The measured pressure is applied outside the bellows. A spring is placed inside. The pressure determines the lift l . Application in control technology (switching or opening of control contacts).

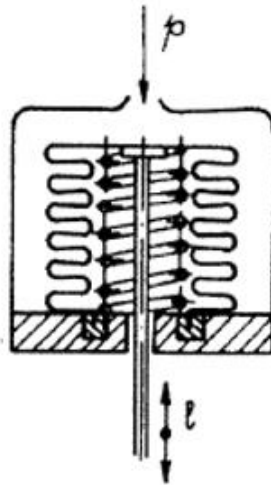

Electric Pressure Gauges

The dependence on some electrical quantities is used.

Classification:

- a) **electrical vacuum gauges:** use either the principle of ionization between electrodes in a chamber with residual air (pressure dependence of current - ionization vacuum gauge) or the pressure dependence of the thermal conductivity of the gas (bolometric vacuum gauge)
- b) **resistance gauges:** use pressure-dependent resistance - only at high pressures (80 MPa to 3 GPa). Compression of the wire cross-section and subsequent change in its electrical resistance.

Flow Velocity Measurement

Velocity Probes

They are used for laboratory purposes or precise, usually one-off measurements. The flow velocity is given by

$$w = \sqrt{2 \cdot \frac{p_d}{\rho}} = \sqrt{2 \cdot \frac{q \cdot s}{\rho}}$$

Pitot Tube

It uses the relationship for the dynamic pressure of the flowing fluid in a closed channel: $p_d = p_t - p_s$.

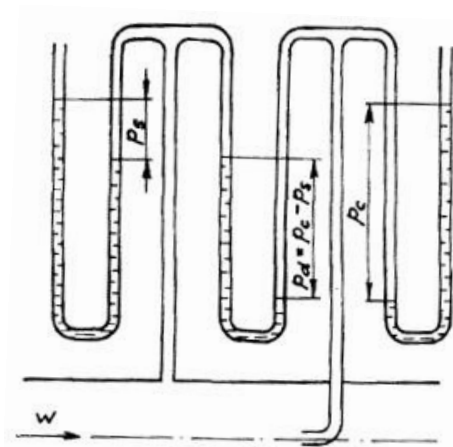

Total pressure (axial connection) and static pressure (wall connection) sampling points. Accuracy is affected by the fact that total and static pressure are not measured at the same place.

Prandtl Tube

Otherwise known as a Pitot static tube, it measures both p_c and p_s pressures in one place. It is a tube bent at right angles. There is a hole at the front of the tube to read the total pressure and holes at the sides to read the static pressure. The lower limit of the measured velocity is determined by the measurability of the dynamic pressure (about 6 m/s water and 0.2 m/s air); the highest measurable velocity is limited practically only by the stiffness of the probe.

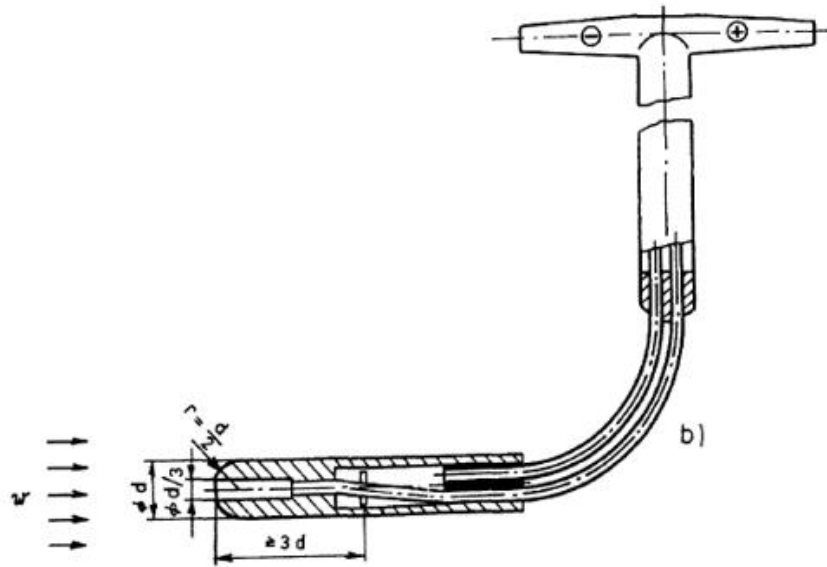

Thermoanemometry

Contact method for measuring velocity and temperature in fluids suitable for measuring turbulent quantities and fluctuations in velocity or temperature.

Principle: convective heat transfer from a resistively heated body-sensor (probe).

- the probe is a weak, usually tungsten (wolfram) wire stretched between the fork tips

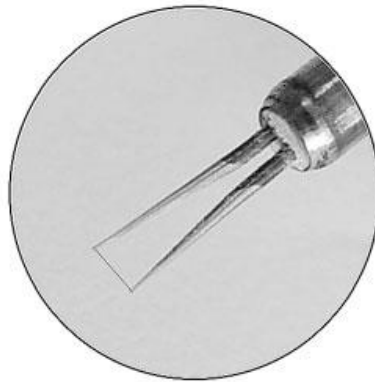

- Joule heat produced by a probe wire of cross-section S_w with a specific electrical resistance ρ_w , through which an electric current I passes: **Joule's law**

$$d\dot{Q}_J = \frac{I^2 \rho_{\text{wire}}}{S_{\text{wire}}} dx$$

- the heat generated is partially accumulated in the probe material, and the rest is dissipated into the surrounding fluid by convection, conduction, and radiation:

$$d\dot{Q}_J = d\dot{Q}_{\text{ac}} + d\dot{Q}_{\text{conv}} + d\dot{Q}_{\text{cond}} + d\dot{Q}_{\text{rad}}$$

- the accumulation term can usually be neglected due to the low heat capacity of the probe material

- the conduction term can be neglected because of the wire dimensions; the diameter is much smaller than the length of the wire (micrometers vs. millimeters)
- the radiation term is significant only at low flow velocities or low-pressure
- zbývá konvektivní člen, který je dán **Newtonovým ochlazovacím zákonem**

$$d\dot{Q}_J = d\dot{Q}_{\text{conv}} = \pi d_w \alpha (T_w - T_\infty) dx,$$

d_w is the wire diameter, T_w is its temperature, T_∞ is the ambient temperature, and α is the heat transfer coefficient

The current in the thermoanemometer circuit is regulated by a **Wheatstone bridge** (an electronic control component consisting of two branches, electrical resistors, and a potentiometer).

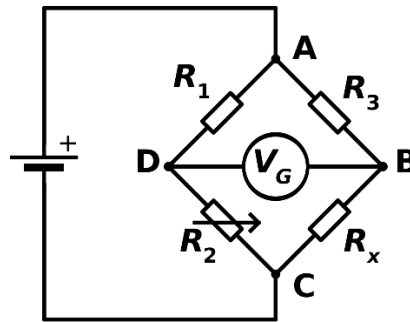

Modes:

- CTA (Constant Temperature Anemometry):** the probe is kept at a constant temperature, i.e. the electrical resistance of the wire does not change
 - with a change in velocity, there is a change in temperature; this is compensated by an additional change in voltage
 - the supplied voltage is a measure of the flow velocity
 - used for accurate measurement of velocity fluctuations
- CCA (Constant Current Anemometry):** a constant current is maintained on the probe
 - as the temperature changes, the resistance of the filament changes, and this changes the voltage at the terminals
 - the voltage does not have a compensating function but is a direct measure of the flow temperature
 - used for accurate measurement of temperature fluctuations

Overheat ratio:

- an important parameter for setting the wire temperature
- velocity or temperature sensitivity is directly dependent on the choice of the overheating coefficient
- depends on the properties of the wire and the flow medium
- the aim is to choose the highest possible coefficient, but the limit is, e.g., the boiling point of liquids or the melting point of wire
- the overheating coefficient is determined by the operating resistance of the wire and the resistance of the wire at ambient temperature

$$a = \frac{R_W - R_0}{R_0}$$

Velocity (Temperature) Calibration

Accurate probe calibration is necessary to obtain quality results. The measurand is a voltage, so it is required to determine the relationship for the conversion of velocity $E = f(U)$ (CTA) and temperature $E = f(T)$ (CCA). The most commonly used relationships for calibration curves are:

- King's law:

$$E^2 = A + BU^n$$

- n is the exponent of King's law set by King to $n = 0.5$ and later refined to $n = 0.4 \div 0.45$

- an expanded King's Law:

$$E^2 = A + BU^{0.5} + CU$$

- polynomial curve fitting:

$$U = A + BE + CE^2 + DE^3 + \dots$$

For velocity calibration, a special calibration device is used to accurately adjust the flow rate through the calibrator nozzle. For temperature calibration, e.g., a calibration furnace/bath or a climatic chamber is used. During the calibration, a sufficient number of discrete velocity or temperature values are measured, typically 10 or more over the range of velocities or temperatures expected during the experiment. The discrete values are then fitted with a suitable calibration function.

Thermoanemometric probes:

- wire probes (single wire for single-axis flow or multi-wire for multi-axis flow): **HWA** (Hot Wire Anemometry)

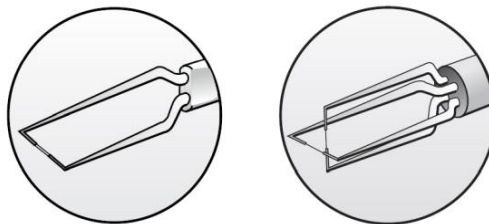

- film probes (probes designed for precise measurement of fluctuations in wall quantities, can be used, for example, for determination of heat transfer coefficient): **HFA** (Hot Film Anemometry)

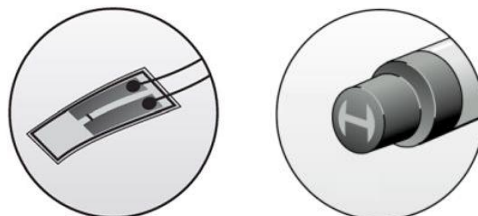

Advantages:

- Easy to use,
- large range of measured values,

- small probe size (5 μm diameter, 1.25 mm length),
- 1, 2, or 3 velocity components (1D, 2D, 3D flow measurement),
- temperature measurement,
- accurate results, high sensitivity, and high signal-to-noise ratio,
- analog signal that can be converted to a discrete signal at high frequency (thousands of Hz).

Disadvantages:

- Contact method (influencing the flow),
- precise calibration required,
- difficulties in determining the direction of the flow,
- susceptibility of the probe to damage, e.g., by impurities in the flow or handling.

Particle Image Velocimetry

PIV is used for visualization and measurement of current fields. It is a non-contact optical method based on the principle of tracking the displacement of tracer particles dispersed in the flowing fluid. The elementary equation is the velocity equation determined from the displacement of the particle Δl over time Δt :

$$v = \frac{\Delta l}{\Delta t}$$

The tracked stream is illuminated by a plane of laser light (laser sheet), and the scattered light by the tracing particles is recorded on the camera. The time Δt is determined by the frequency of the pulsed laser, the distance Δl by the displacement of the particles in the image plane. The recording needs to be recalculated to the object plane (laser sheet) using spatial calibration.

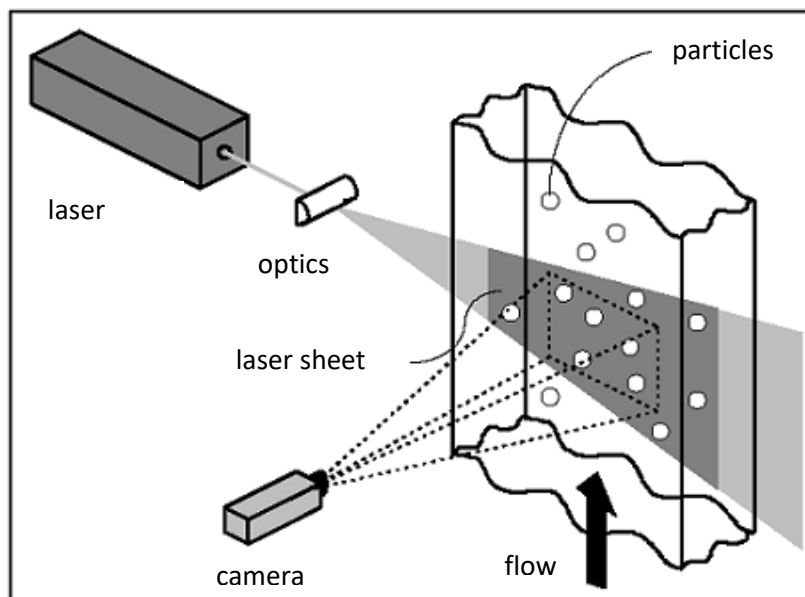

Recording modes:

- a) **double exposure (single frame):** the initial and final state of the particle distribution is recorded in a single frame

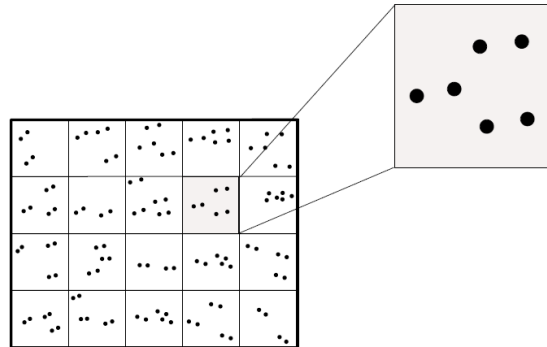

- b) **single exposure (double frame):** the first and second exposures are recorded separately

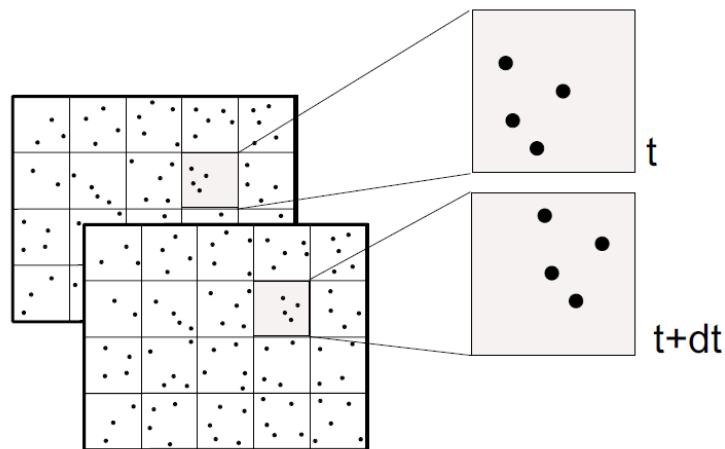

PIV image analysis:

The PIV image is divided into a mesh of small interrogation areas (most commonly 64×64 , 32×32 , or 16×16 pixels). In the squares, a displacement vector is independently searched using algorithms that look for correlation in the displacement of the particle pattern. Depending on the way the image is recorded, it can be classified as **autocorrelation** (double exposure) and **cross-correlation** (single exposure). A correlation map is created: a 3D representation of the probability of particle displacement in the square under evaluation. The correlation map is performed using the fast Fourier transform (FFT).

- a) **The autocorrelation** produces one central peak in the correlation plane and two centrally symmetric peaks defining the "average" displacement s_a in each evaluation region. The direction of the velocity vector is ambiguous.

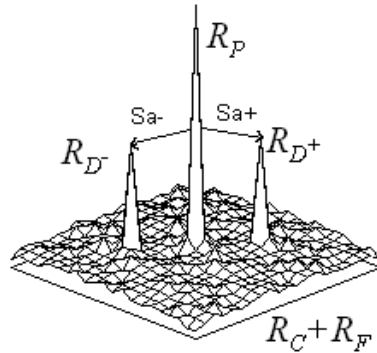

- b) **The correlation** produces a single peak whose distance from the center of the region under evaluation defines a displacement vector s_a . The direction of the velocity vector is unambiguous.

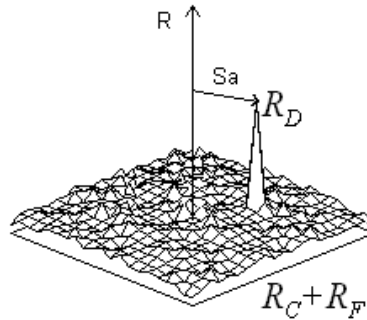

The exact position of the correlation peak is found using **subpixel interpolation**, which is fitting correlation values in the correlation plane over individual pixels by a Gaussian curve. The accuracy of the vector size determination is up to a tenth of a pixel for the cross-correlation. For autocorrelation, the accuracy is an order of magnitude lower.

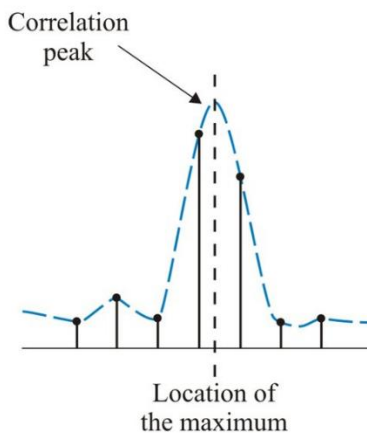

In addition to the correlation peaks, there is correlation noise in the correlation map. Its level depends on the PIV system's digital and optical noise and the raw data quality. Good quality results require a sufficient signal-to-noise ratio. The result of the PIV measurement is a **vector map**.

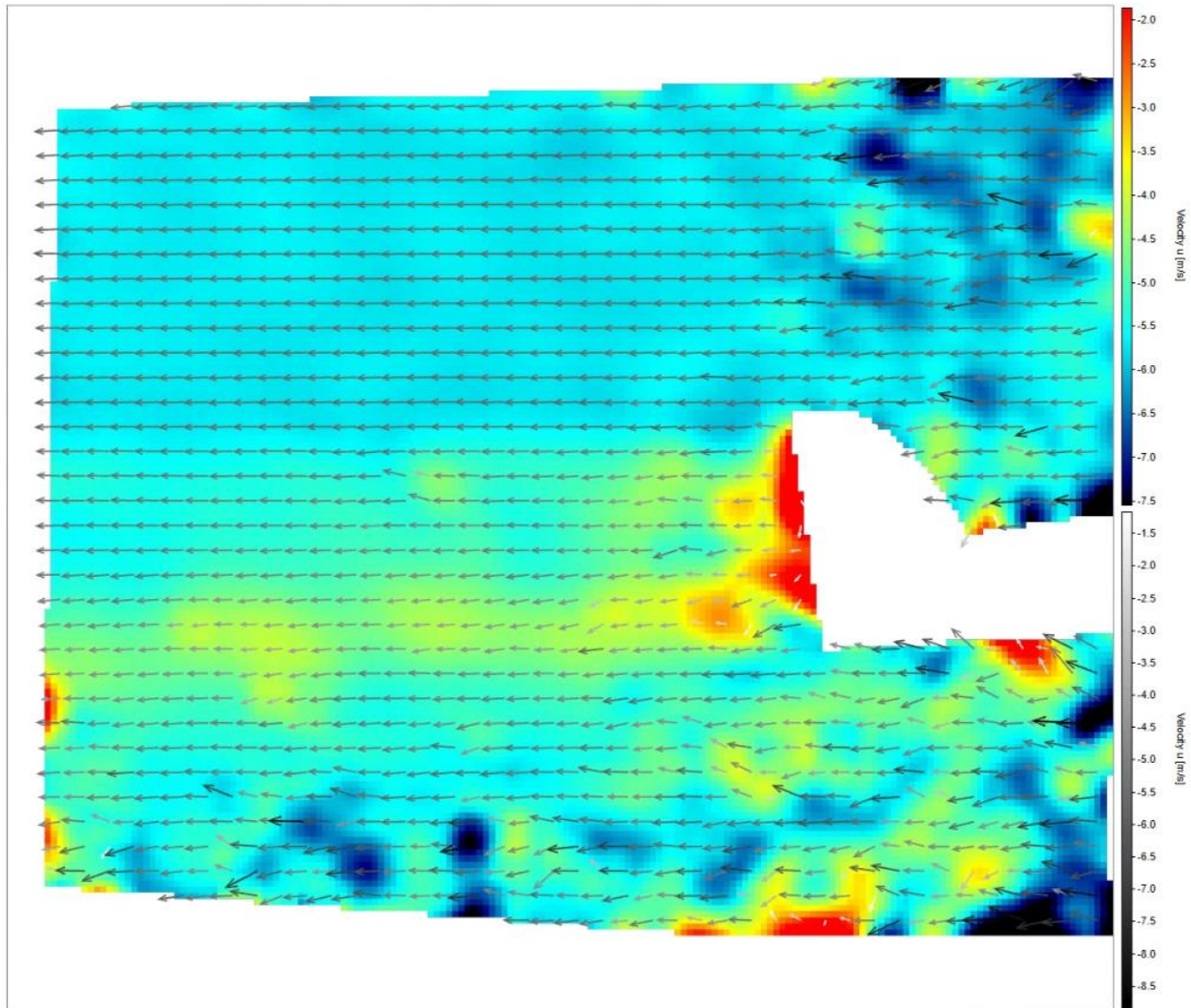

The correlation algorithm requires finding pairs of particles between exposures to work correctly. In case a particle between laser pulses leaves the interrogation window, it is a so-called **lost pair**, and this particle is unusable for the calculation. This causes the most common systematic error in PIV, which can be minimized by sufficient saturation of the stream with particles and by proper choice of the interrogation window size relative to the measured velocities. For this reason, it is necessary to have enough particles in each evaluation window. For single exposures 5 and double exposures 10 are given. However, when the interrogation window is enlarged, the spatial resolution is reduced, and smaller vortex structures may not be captured. If the smallest vortex structure is smaller than the area to be evaluated, the width of the correlation peak increases, which can be interpreted as higher measurement uncertainty.

Calibration:

Calibration of the system is necessary because the coordinates of the image plane are in pixels, and the image plane is not perfectly parallel to the plane of the laser sheet.

Calibration can be done in two ways:

- a) **Two-point scaling** is used when a calibration plate cannot be used. Two points with a known distance are determined in the image plane. This cannot be used in the case of non-linear optics (fisheye, etc.). At the same time, the camera must be perfectly perpendicular to the laser plane, and the image must be undistorted (refraction of light on glass, in water, etc.).
- b) Calibration with a **calibration plate** is the ideal calibration method. This way, non-parallelism of the image and object planes, optical non-linearities, and distortions can be corrected. A calibration plate is usually a dark plate with bright points arranged in a defined pattern. Calibration is performed by recording a calibration plate placed in the object plane. Subsequently, the constants of the mapping functions used for coordinate recalculation and velocity calculation are performed by software.



Digital Holographic Interferometry

Interference: the combining of individual waves into a superposed wave. The result of wave interference is an interference pattern.

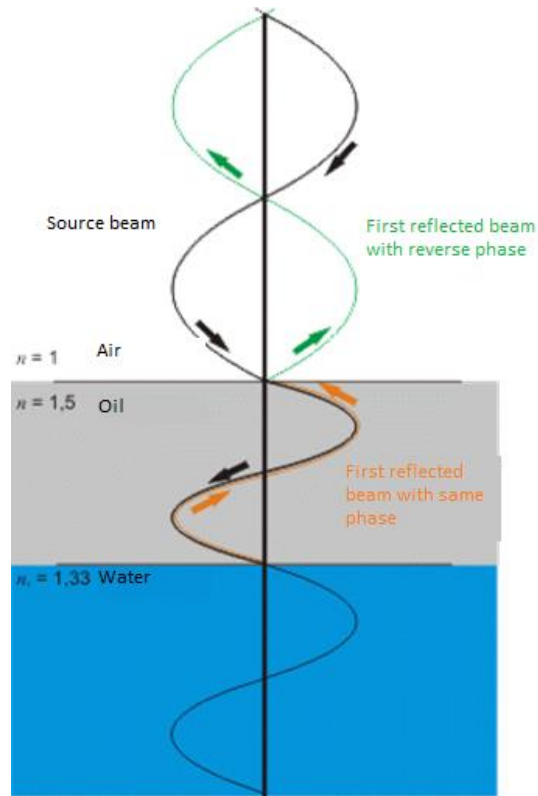

Interferometry

Fizea's interferometer: the laser beam passes through a semi-transparent mirror, collimating optics and a wedge plate to the tested surface. The beams are reflected from this and interfere with the reference beam reflected from wedge plane behind the reference surface. Using the mirror, the interfering waves are directed into the camera and recorded as interference stripes.

- Surfaces of optically smooth surfaces can be measured (specular reflection).
- High accuracy (fractions of a wavelength).
- Cannot measure surfaces with diffuse reflection.
- Challenging experimental setup.

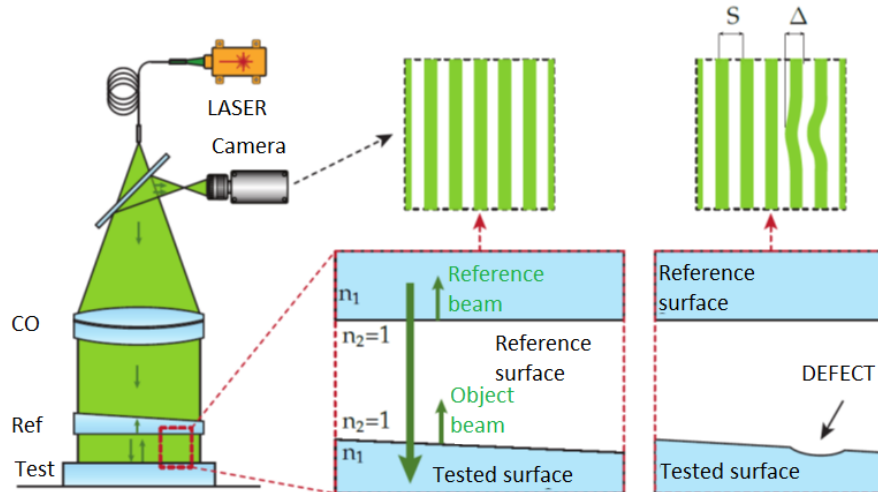

Holographic Interferometry

Hologram: holos = total, graphein = to write down. The holographic plate, in contrast to a photograph, does not only record the intensity but also the phase of the waves.

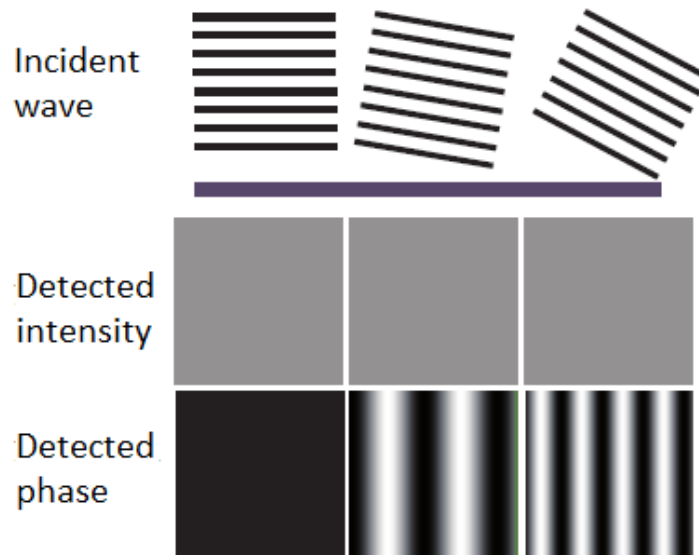

Holographic Interferometry:

- Reconstruction of interfering waves from a hologram.
- While classical interferometry compares a reference wave with the state of an object, HI compares two different states of the same object.
- The interference patterns behind the hologram are a record of the phase difference between the two states.
- The phase difference can be converted to a desired quantity.
- Digital HI is a digital modification of analogue HI.

Recording:

- The object and reference wave is recorded in a hologram on a holographic plate.

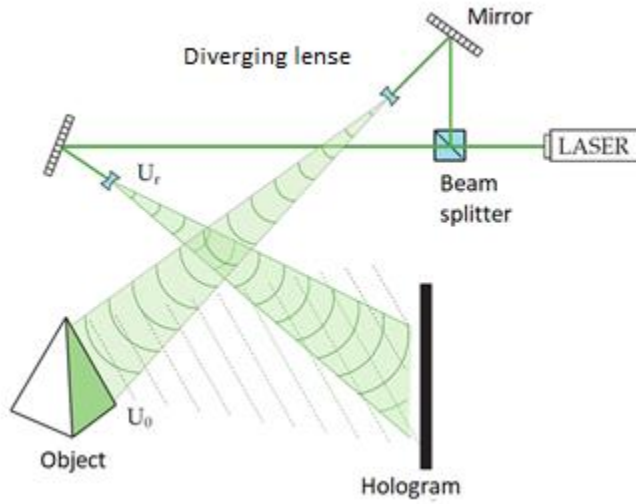

Reconstruction:

- The hologram is illuminated by a reference wave. The reconstructed wave propagates behind the hologram.

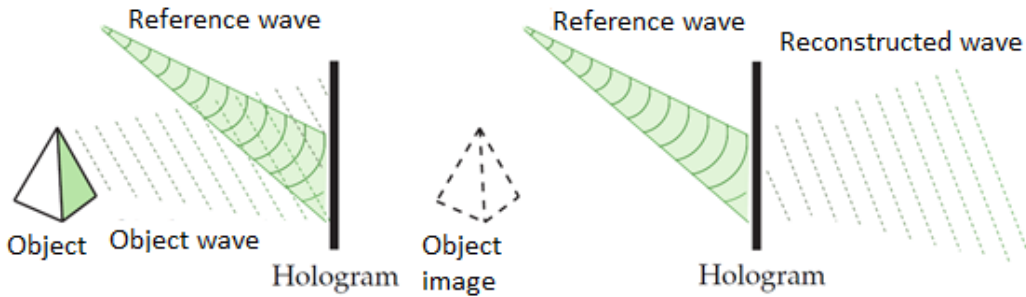

Digital Holographic Interferometry

Recording:

- The object and reference waves are recorded directly by the digital camera.

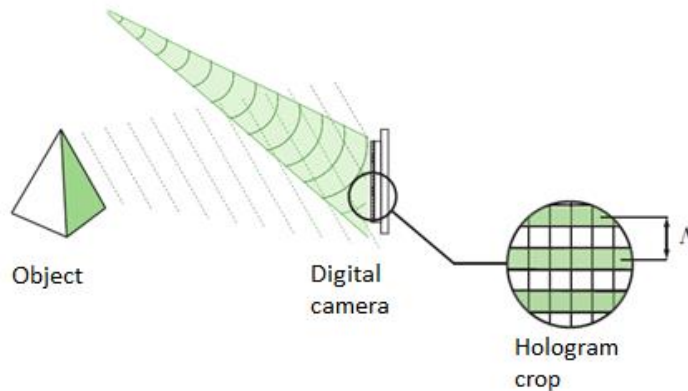

Reconstruction:

- Hologram reconstruction in the case of DHI is a purely numerical process.

Usage:

- Measuring the change in shape or displacement of an object.
- Measurement of harmonic oscillation.
- Measurement of the shape of objects.
- Measurement of refractive index distribution and conversion to density or other properties (temperature, pressure, velocity or concentration).

HI and DHI properties:

- Non-contact, non-invasive and non-destructive measurement,
- high sensitivity,
- ability to record changes over a long time interval,
- the possibility to measure through windows and portholes and thus isolate the object to be measured in vacuum or pressure chambers,
- less demands on the quality of the experimental set-up than in the case of classical interferometry, since only the phase difference between the waves is monitored,
- can be used to measure moving surfaces using short pulses of a pulsed laser,
- possibility to measure vibrations,
- diffuse surfaces can be measured,
- the shape and size of the object to be measured are practically not limited, the size of the objects can be in the order of micrometers or even meters,
- can be used to measure different states of matter, the strength of solids is also not limiting,
- high measuring range; strain in the order of fractions of a wavelength up to thousands of times its value,
- the resolution and accuracy of the instrument can be used to calculate mechanical stresses,
- one hologram records different viewing directions simultaneously, which can then be reconstructed separately,
- mirror surfaces cannot be recorded,
- experimental and theoretical complexity,
- high acquisition costs of the laboratory.